

3 Bow Bimini Boat Tops

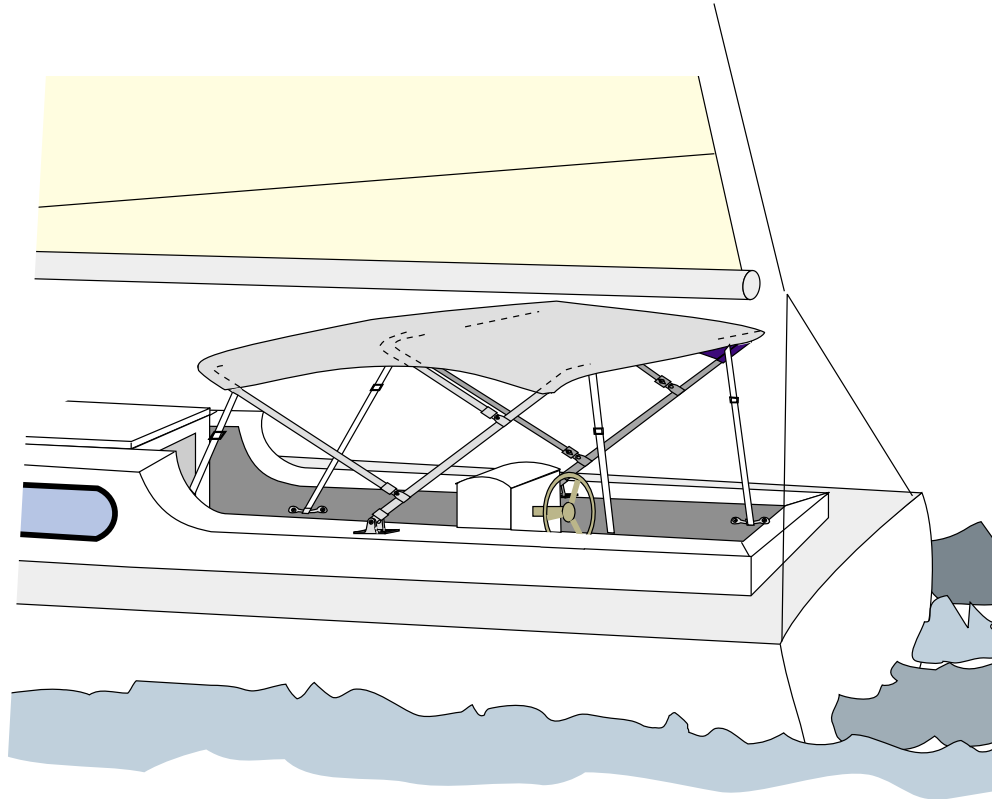

We all like to sail on bright, sunny days. But too much sun has ruined many a cruise. So have rain and drizzle. A bimini extends the range of "comfortable" sailing greatly by providing shelter from the sun or from rain without creating a "closed in" feeling. It can, of course, be used when under sail or at the dock. It can also be folded away when not needed with very little effort.

The Bimini we discuss here is a simple one. Only the sleeves and tails along the forward and aftward ends are likely to cause

some head scratching. These sleeves feature zippers so the Bimini cover can be quickly removed for storage or cleaning. We have used a binding tape all round the cover instead of a hem in order to simplify construction. Many professionals do the same. Indeed, the results of your effort will easily match the work of professional canvas shops. Building a Bimini is fun and satisfying. Let's go to it!

The Frame

Start by constructing the frame. The three bow Bimini we are going to discuss here

requires nine tubing parts. Sailrite provides prebent 7/8" anodized aluminum or 1" stainless steel tubing. The former is quite inexpensive while the latter provides maximum strength and, thus, durability.

Each complete bow assembly is made up of three parts: a center tube with a slight upward curve (called a crown) and two "hockey stick" shaped pieces of tubing. These three tubing sections are joined together with short tubing "splines" that slide into the sections. (More about this latter.)

Two of these bows will have long legs and one will have somewhat shorter legs. The bows should be assembled as shown in Figure 1. The short bow should be secured to the aft long bow. It should be mounted on two sliding jaws so that it supports the center of the Bimini. And it should be designed so that it folds neatly in between the other two bows so that the frame can be compactly stowed when not in use.

All fittings are illustrated in Figure 2. They are secured in place with set screws. This makes the disassembly of the frame quite straightforward.

Before cutting any of the frame pieces, make a trip to the boat and determine how high and how wide and how long the finished Bimini should be. I like to take the frame with me and tape it in place on the boat while making these measurements. You may want to wait to actually cut the frame in a more comfortable environment, but it helps to temporarily support the full size frame in place

Figure 1

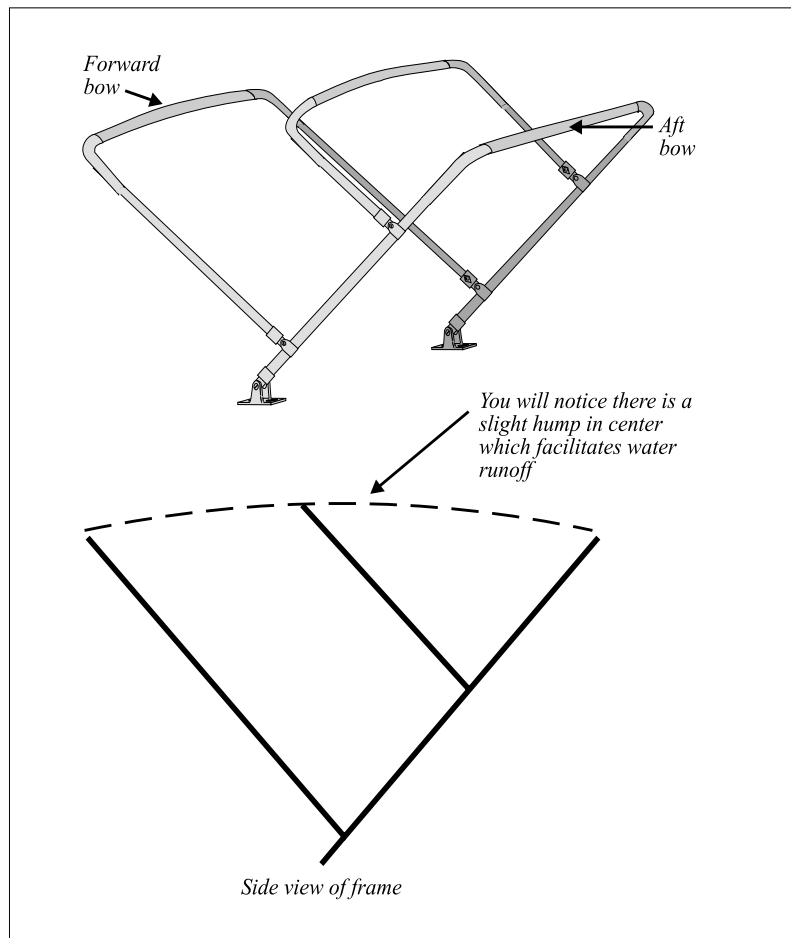

on the boat to approximate how it will look and feel when it is finally fitted. Ideally, the Bimini will permit one to stand in the cockpit and look out under the edge of the fabric without having to stoop. But be sure that the Bimini is not so tall that the free movement of the boom across the boat is inhibited. When you are done, you should have a measurement for the proper width of the frame at the base of the legs, for its height from the plane of the leg base to the plane of the fabric cover, and for the length of the cover from the front bow to the back bow measured at the center of these two bows.

Figure 2

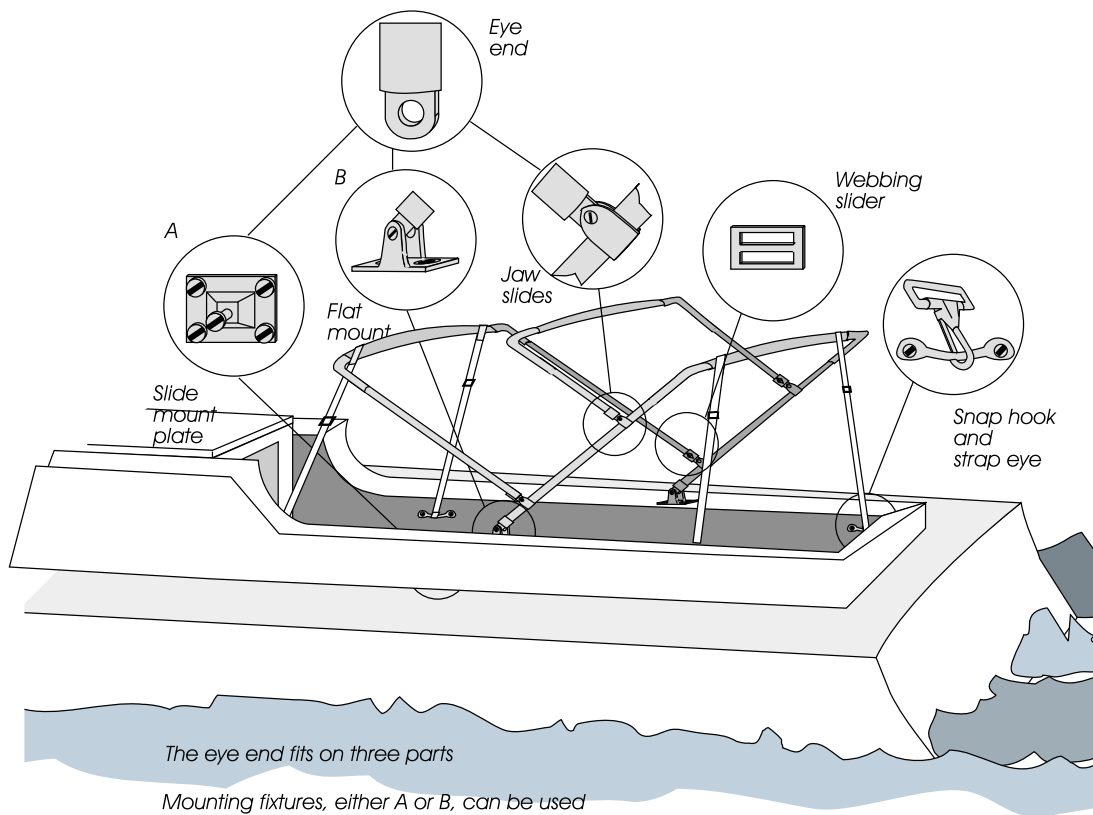

Armed with these measurements, prepare a frame using two by fours. Place the frame on the floor of your work area. The two frame side boards should be on center just the desired width of the bimini frame at its base. They should be about two feet longer than the overall length of the Bimini. Such a board frame is illustrated in Figure 3.

Screw your mounting plates in place on the frame and assemble the bows. Note, if your Bimini requires side mounts, you must mount a block of wood centered along each length of the wood frame. These two blocks should be tall enough to facilitate securing the side mounts to the frame. Cut the legs as needed to create the proper height and spread fore and aft (see Figure 4). Cut the straight tubing that connects the curved legs so that the width will be appropriate. It is a good idea to leave the center tubes about six inches longer than a perfect fit would require. It will then be necessary to compress the frame legs together when mounting them. That makes the bows more ridged and tends to put a little extra arch in the top of the frame which (in my opinion) makes the frame look a little more graceful.

Figure 3

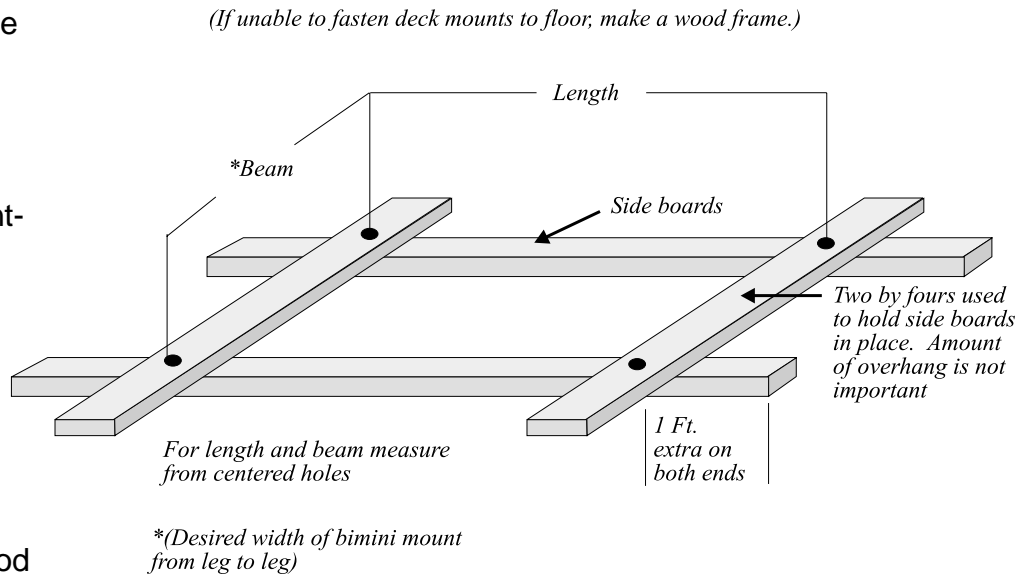
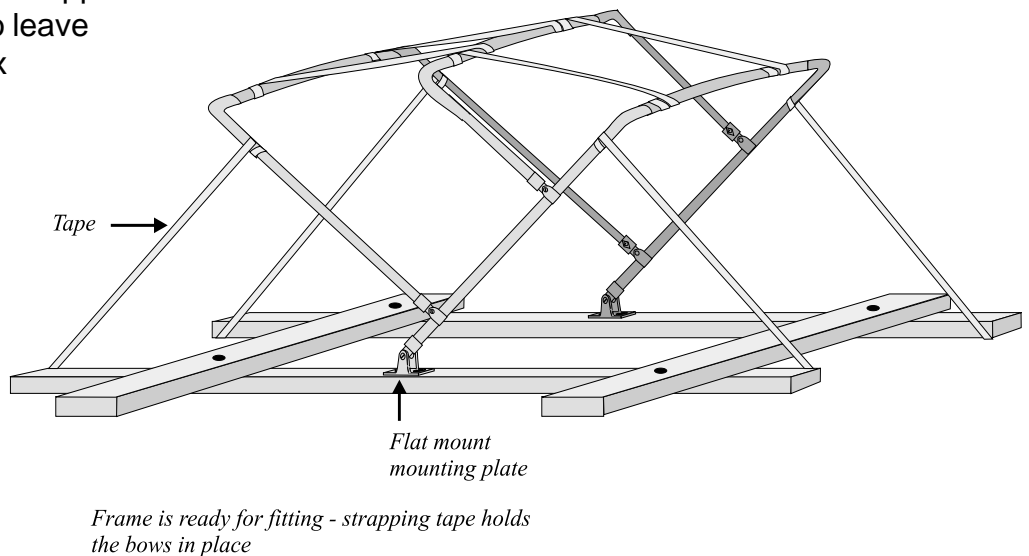
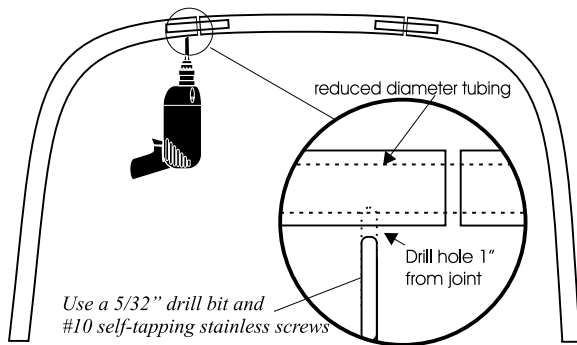

Figure 4



After cutting the frame width, tape the bow assembly back together. Be sure the spline tubing is inserted equally in the leg and the center piece and that the center piece (if crowned) is up.



With each bow lying on a flat surface, use a 5/32nds inch drill bit to make two pilot holes (one on each side of the joint where the two frame pieces meet). Drill through both the frame piece and the reduced tubing. Be sure to drill up from the bottom of the frame so that, when the screw is inserted, it will not come in contact with the fabric. If a center punch is used first to make a "dimple" for starting the hole, drilling will be easier.

Now lock the coupled bow segments together using the #6 stainless steel, 3/8" self tapping pan headed screws included with the dodger kit (Figure 6).

With stainless bows we find that the self tapping screws often break or the threads on the screws are simply worn away by the tough stainless. To resolve this problem we recommend that a #21 drill bit be used to open the hole and that the outer tubing be tapped. Use a 10-32 tap and, of course, a 10-32 machine screw.

Use strapping tape (the "filiment tape" used to close boxes works well) to first secure the center bow properly between the other two bows. Then use the tape to pull the fore and aft bows apart. Make these latter tapes very tight so that the frame becomes extremely ridged. We don't want it to move at all while we work with the fabric cover material. When you are done, step back and check to make sure that the frames are equal in height (the center bow should be slightly higher than the other two) and level.

Fitting the Fabric Cover

Begin by cutting and sewing (if necessary) a rough blank of cloth that is 17 inches wider than the beam of the frame at its base and 36 inches longer than the length from the center of the forward bow to the center of the aft bow. The extra length is for the sake of making sleeves for the bows. No other material will be required.

I usually find it necessary to sew two lengths of the 46-inch wide acrylic material together to provide sufficient width. This puts a seam right down the center of the top. It is also ok to join the panels so that the seam runs across the width of the boat if that results in a better use of cloth, but keep the seam close to a bow so that the cloth is "tent" over the seam. That will keep it from leaking water.

To join cloth panels, simply overlap two appropriate lengths of cloth about 3/4" and place two rows of straight or zigzag stitches down the seam sides (Figure 5). A double sided basting tape will make this sew-

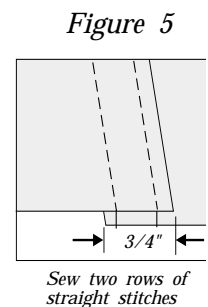

ing process very accurate and that is required if the top is to be made wrinkle free. When basting it is best to start at one end of the fabric and tack the first few inches of the panels together. Then place your knee on the tacked area to hold it in place. With your right hand push the bottom layer of cloth away from your knee. Cup your left hand over the top layer of cloth pulling this cloth over the bottom layer. Apply pressure with your thumb to baste the two panels together in about two foot sections at a time. Be sure not to stretch one piece more than the other. Doing so will cause wrinkles along the seam.

Figure 6

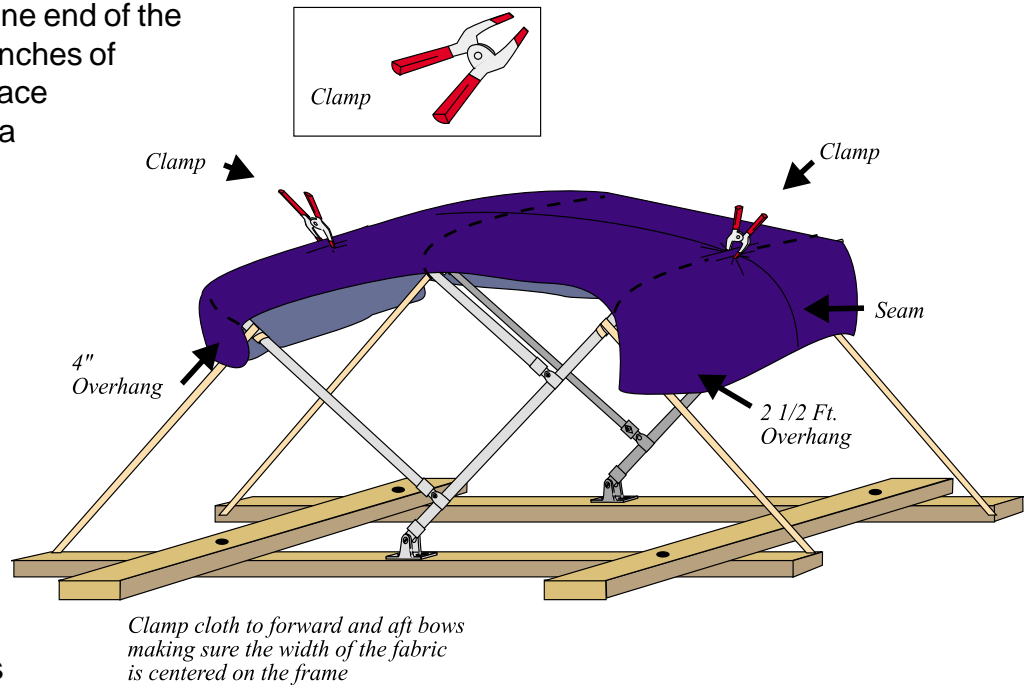

If you plan to use a straight stitch, your machine should be adjusted to make the longest stitch of which it is capable since that reduces the natural tendency for acrylic material to pucker as it is sewn. Zigzag stitches, however, should be relatively small (about 3/16-inch per "leg") as they tend to snag on boat appendages. Don't worry, however, about small amounts of puckering since it will come out very quickly in use.

Drape the blank over the frame. Make sure that it is centered across its width. Allow a 4-inch overhang at the forward bow (i.e., the bow without the attached center bow should be mounted so that it is toward the bow hence, "forward"). Wrap the fabric round the tubing at the center of the bow and use a large clamp to hold it in place. Pull the blank tight at the same place on the aft frame and clamp it there (Figure 6). There will be over

Figure 7

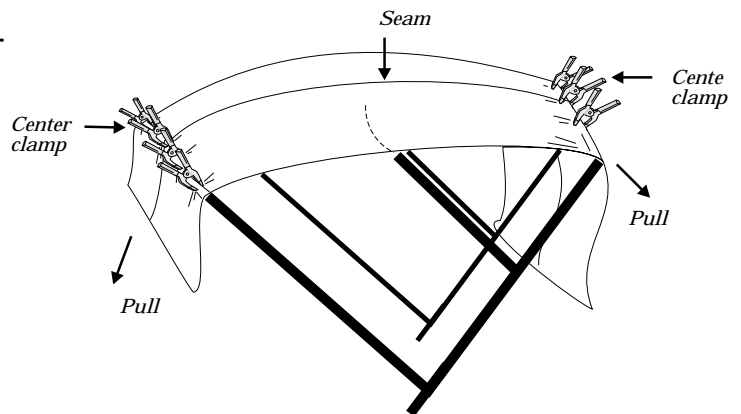

Start at the centered clamps and stretch the cloth out between the forward and aft bows. Clamp along the bows on three to six-inch intervals drawing the fabric tightly as you go.

2.5 feet of excess cloth hanging over the rear bow. This will be used later to make sleeves.

Now stretch out the cloth along the aft and front bows. Start at the centered clamps. Pull first on one side and then on the other at three to six-inch intervals drawing the fabric tight and clamping it as you go (Figure 7). There will come a point near the sharp bend in the bows where pulling from the front and the rear will not remove all the wrinkles in the fabric. In order to solve this problem, it is necessary to create a pair of darts over the center bow that will remove excess material. These darts are measured and marked on the cloth in the steps that follow.

In order to measure and mark these darts we must stretch the cloth between the center bow and the two end bows. Start at the forward bow and pull the cloth snugly down around one curve. Clamp it in place there and then push the cloth down just behind the center bow on the same side until all wrinkles are removed. Continue down around the curve until there is enough extra cloth behind the center bow to place a clamp. See Figure 8.

Then use a pencil to mark the front side of the dart. The pencil line should be drawn right over the top of the center bow tubing (Figure 9). Your marks should begin about 12 inches before the bow begins to curve. (Figure 9). Skip over the clamps, the broken areas can be drawn in later.

Leave all the clamps in place on the side just completed and follow the same process on the other side of the Bimini's forward

Figure 8

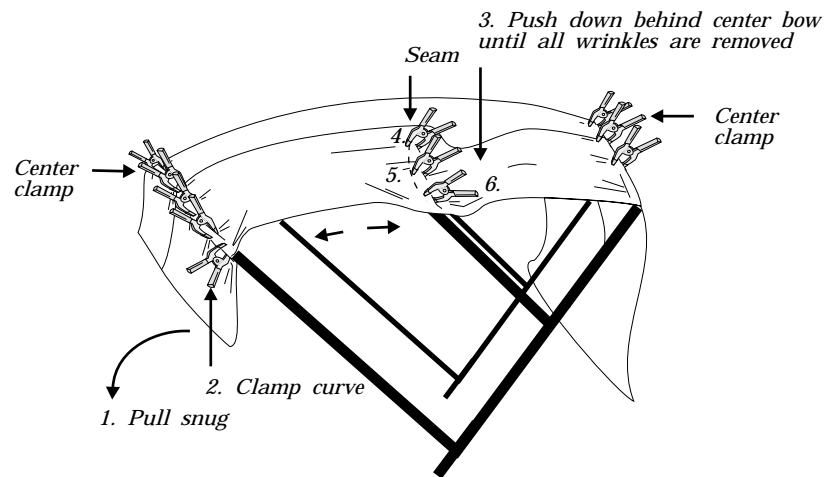

Clamps 4, 5 & 6 - Clamp the cloth then pull cloth towards the curve of the center bow. Continue this process after each clamp insertion.

Figure 9

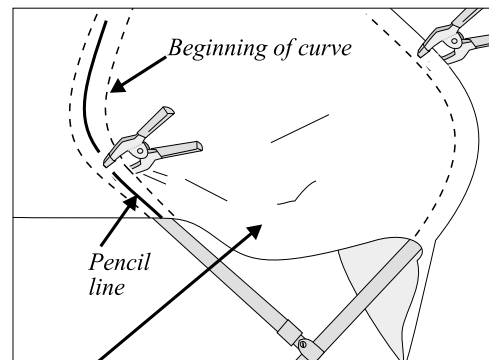

Push down in this area until the fabric in front of the center bow is tight

Figure 10

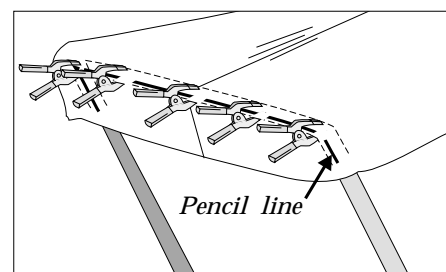

Mark along forward bow's front edge

section (the forward and middle bows). Then use your pencil to place a mark all along the fabric that is draped round the forward bow. This mark should be on the “front” side of the tubing (Figure 10). Again, skip round the clamps.

The sides of the top should now be marked between the forward and center bows. The fabric should extend all the way round the curve in the bows if it is not to look skimpy. Yet it should not continue very far down the legs or it will interfere with your vision. When the proper ending point has been determined (I like to see approximately four inches hang down from the center of the curve of the frame), mark the fabric and measure the distance from this point to the floor so that the opposite side and the two aft points as well will be the same. Place similar marks on the fabric at the center bows, but raise them three inches above the others (Figure 11). This will give the top a more graceful appearance and also counter the tendency for the fabric to ride up the center bow curve as tension is applied from the front and rear.

Remove the clamps that are near the curve of the center bow. And repeat the process described above for the rear section of the Bimini. See Figure 12 for a step-by-step illustration of marking the rear section of the Bimini. When you mark the dart lines, they should designate a narrow wedge of cloth with its point 6 to 10 inches inside the curve of the bows. Note that the mark on the center bow that was placed to designate the width of the top will not serve as an accurate guide for the rear dart—place a new mark at the proper height (Figure 13).

When the blank is removed from the frame, it will look somewhat like Figure 14.

Figure 11

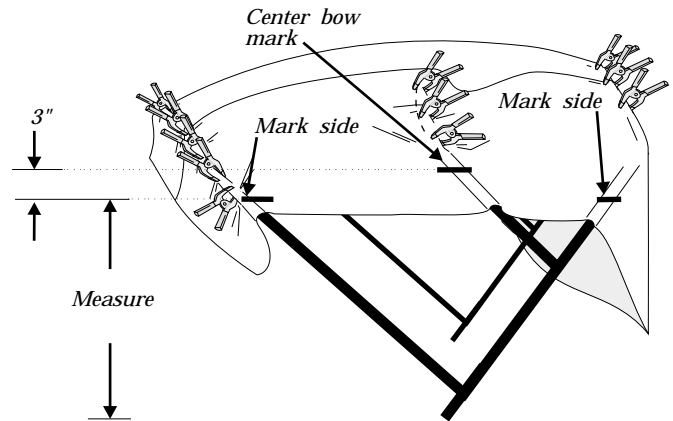

Figure 12

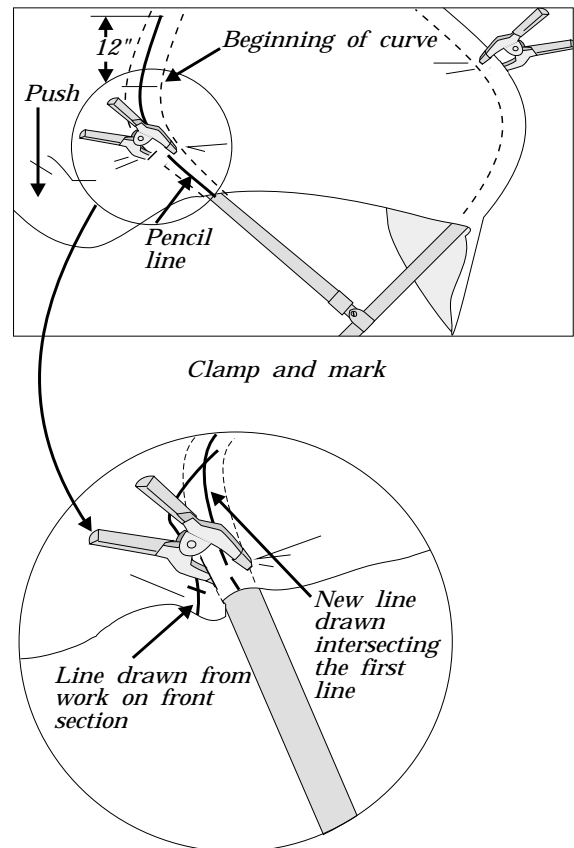

Figure 13

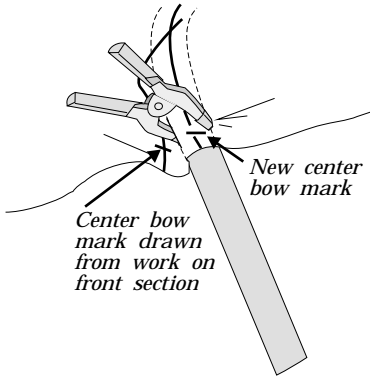
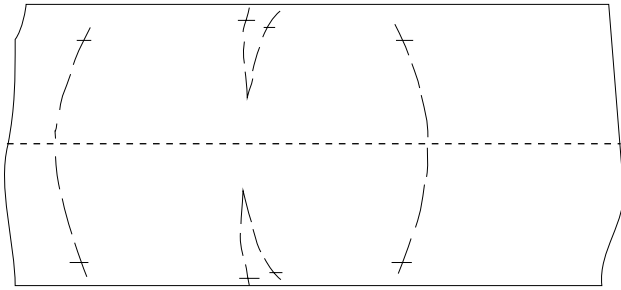
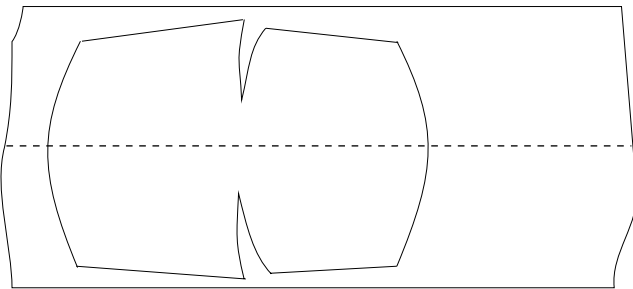

Figure 14



Cloth blank after markings

Figure 15



Cover with sides drawn in

Figure 16

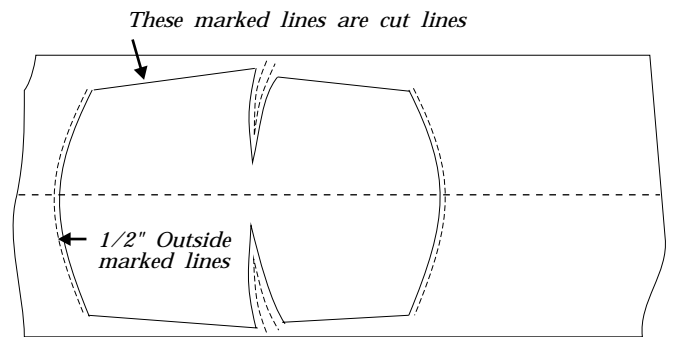

Cut lines for front, rear and darts

Connect all your lines to fill in for the clamp gaps. Also connect the marks along the sides of the top from front to center and from rear to center (Figure 15). These later lines are actual cut lines but all the curved lines are sewing lines which means that a 1/2" seam allowance should be added to them before cutting (Figure 16). All cutting should be done with a hotknife to prevent the cloth from raveling.

When the cover is cut, turn to the sleeves that are used to secure it to the frame. There will be two long sleeves along the forward and aft edges of the top. Slide the part of the blank that was cut away from the aft bow under the aft side of the top (Figure 17). Each sleeve should be 5 inches wide, so slide that much cloth under the top and trace along the end of the material so that the sleeve will have exactly the same shape as the top itself. Note that the original seam in the sleeve should be directly on top of the original seam in the top, i.e., the two should be accurately centered over one another. Mark the corners and also place 8-inch match up slashes that leave marks on both the top and the sleeve (Figure 17). These will ensure that the sleeves can be sewn in place accurately along their length. Write the words "inside," and "front" or "rear" on the sleeve to guide your work in subsequent steps. Repeat this process for the sleeve at the leading edge of the top. Use the remaining material cut from the aft edge of the blank. Here it will probably be necessary to mark the curves along both sides of the sleeve since the forward curve will not match the aft one (Figure 18). Just make sure that the

Figure 17

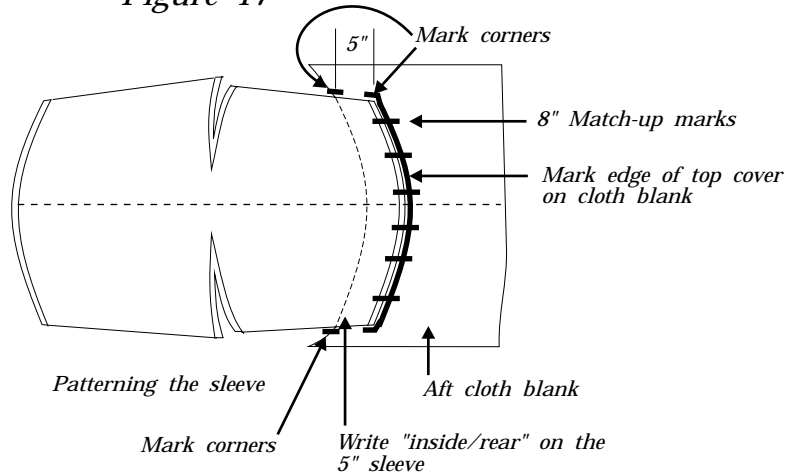

Figure 18

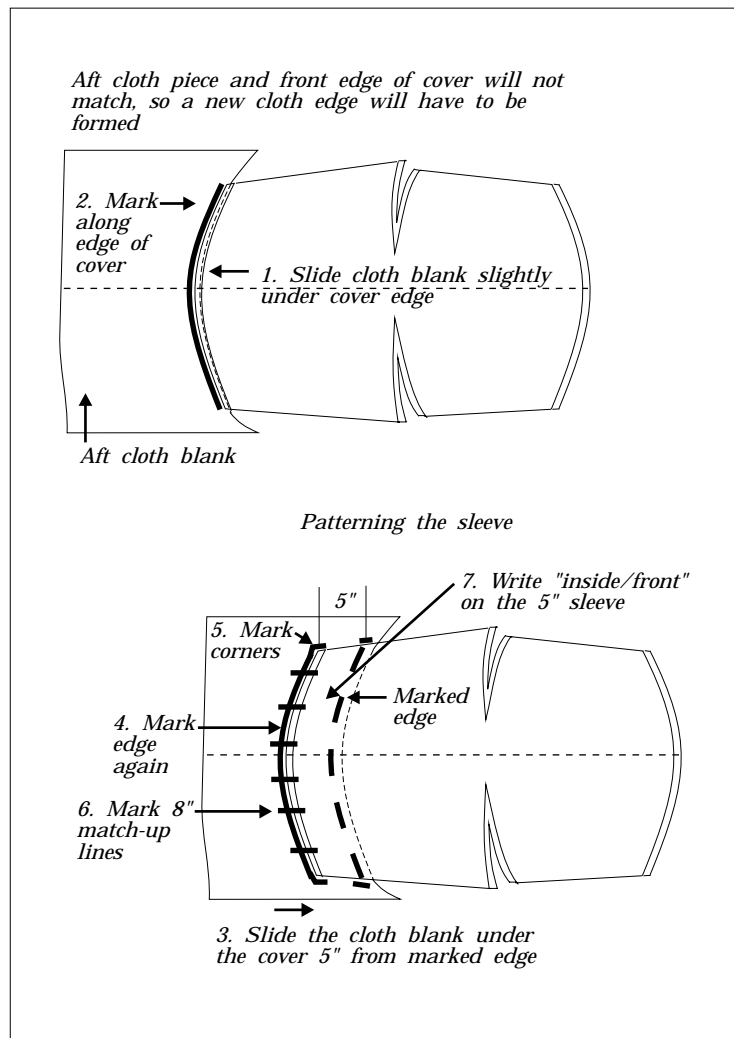

Figure 19

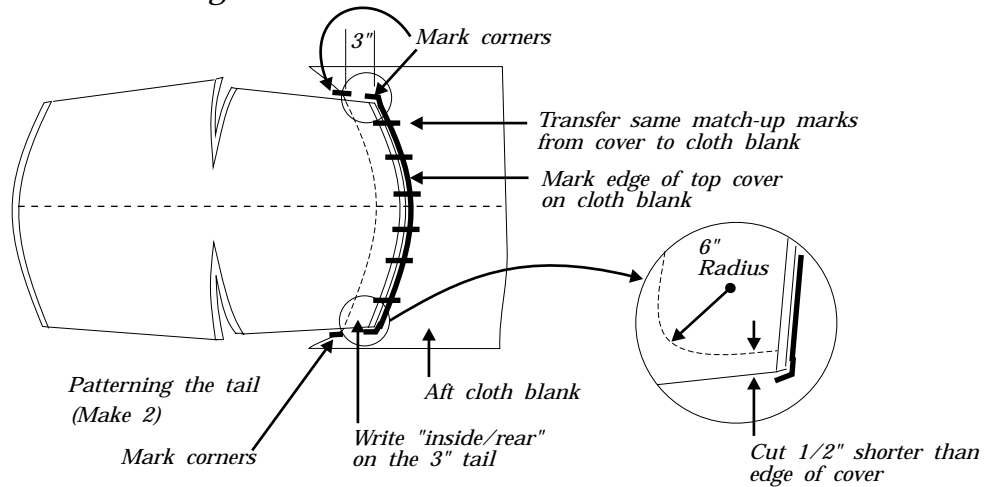
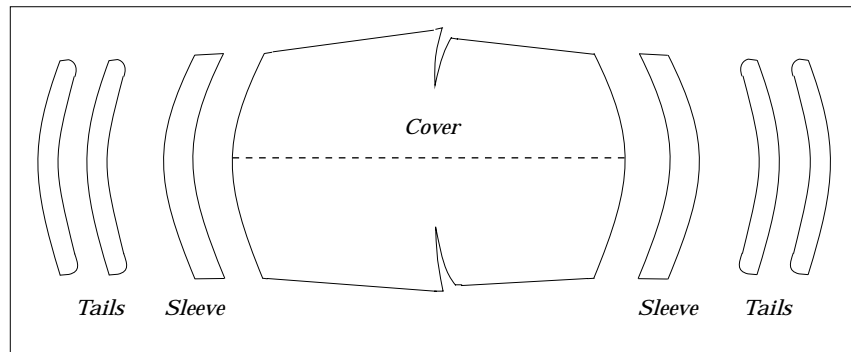

Figure 20



Pieces shown

sleeve is 5 inches wide all along its length. Don't forget the match up marks.

"Tails" are placed at the forward and aft ends of the top. They provide two functions. First, they tend to keep rain or spray from wicking back along the underside of the top to drip on those underneath it. Second, they provide a handy flap to which additional covers or curtains can be attached.

Proceed just as you did when cutting the fore and aft sleeves except make the tails 3 inches wide. Be sure to transfer the same

match up marks that are on the top to the tails. And also mark the tails with the "inside," and "front" or "rear" legend. When cutting the tails, it is a good idea to make them 1/2-inch or so short on the sides to reduce the thickness of the finished top at the corners. The inside corners should be rounded with a radius of about 6 inches. Duplicate each tail (Figure 19). The copies will be used as a reinforcement. Figure 20 shows all the pieces you should have at this stage.

Sewing the Bimini

Begin the sewing operation by closing the darts. Fold the material so that the inside surface (the side with marks on it) is exposed and the cut edges of the dart are on top of one another. It is helpful to staple the fabric along the open darts to position it properly prior to sewing. The side marks made on both sides of the dart must match—if they don't, take the staples out and do it again. Then sew along the pencil lines removing the staples as you sew (Figure 21). Fold the seam allowance aft and run a row of top stitches along the side of the dart to hold it in place (Figure 22).

The outer 6 inches of the forward and aftward sleeves should have a “doubler” reinforcement. Lay these doublers on the sleeves and fold over a 3/8-inch hem at their ends. Use a row of straight stitches to lock the assemblies (the sleeve and the doubler) in place. See Figure 23. Then cut a matchbook sized notch in the outer edge of each sleeve (note that there will be two layers of cloth here because of the doublers) at both ends just 1.5 inches from the corners of the top (Figure 24). These will be used as exit points for the webbing straps that run fore and aft to hold the Bimini frame in place. Fold the cloth from the cutout back on itself inside the sleeve and its reinforcement patch to provide a reinforcing hem. See Figure 24.

Secure two finished zippers to each sleeve along the zipper edge (see Figure 23 & 25) so that the zipper tapes will be inside the sleeve when it is secured to the underside of the top. Simply install the zipper along the outside of the sleeve on the zipper edge. First separate each zipper. Either side, i.e., the one with the zipper tab or the one

Figure 21

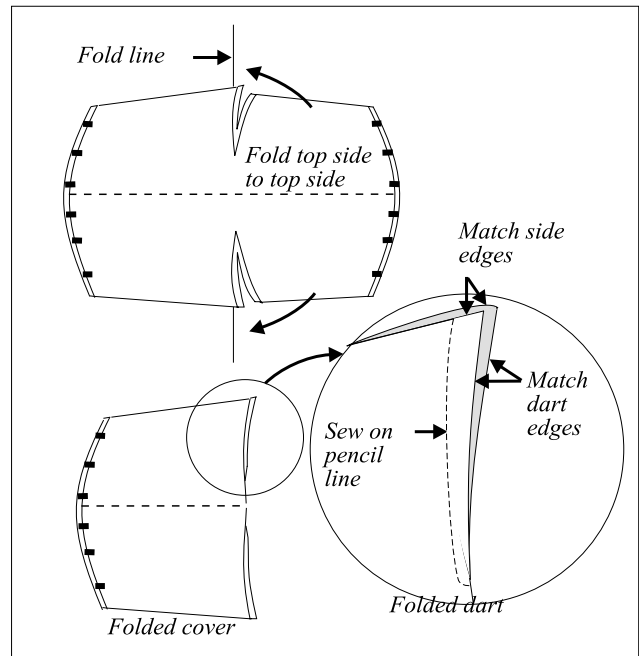

Figure 22

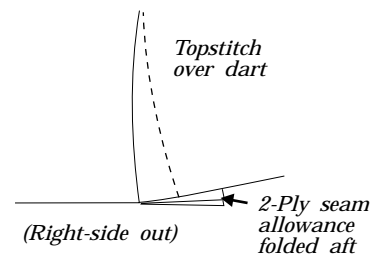
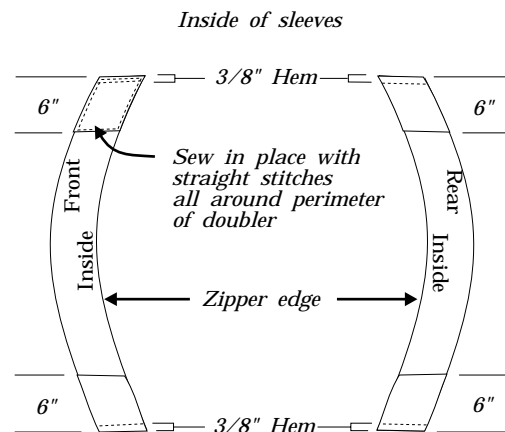

Figure 23



without, can be installed along the sleeve. Which ever way you go be consistent. Two zippers go along each zipper edge (a total of four zippers). The zippers should close last at the cover's widthwise center (Figure 25). Place one half of each zipper on the sleeves as shown in Figure 25. If they are so long that they overlap in the center, simply cut them so that there is roughly a 1/2-inch gap and cut a single tooth from the waste. Insert this tooth between the final two teeth (after first installing the zipper slider on the appropriate side if it is not already there). Then melt those three teeth together to form an attractive stop for the slider. The other side of the zippers can then be sewn directly to the Bimini with a couple rows of stitches. This should be done after the sleeves are attached to the top (we will come back to this later in the instructions). Now sew the zipper tapes to the sleeves with a row of straight stitches with the presser foot right next to the zipper teeth (Figure 26). Fold the zipper tape under as shown in Figure 27. Make the fold wide enough that a flap of cloth is created that nearly covers the zipper teeth. Put a row of straight stitches all along the inside edge of the folded material (Figure 27).

Sew the two parts of the tails together by placing a 7/8-inch binding tape along the right and left and inside edges (Figure 28). Make sure that the match up marks show on the side of the tail that will be up when it is placed over the inside surface of the top.

Now place the top so that the inside surface is up. Lay first the sleeves in position at the fore and aft edges and then the tails on top of the sleeves as described (Figure 29). The raw edge of the tails should be flush with the aft and forward edges of the top respectively. Staple everything in place carefully. Make sure that the match up marks are all aligned.

Figure 24

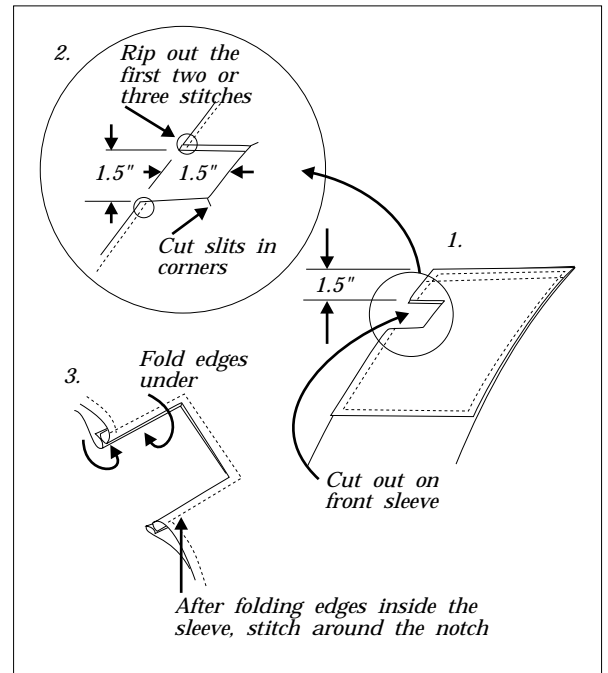

Figure 25

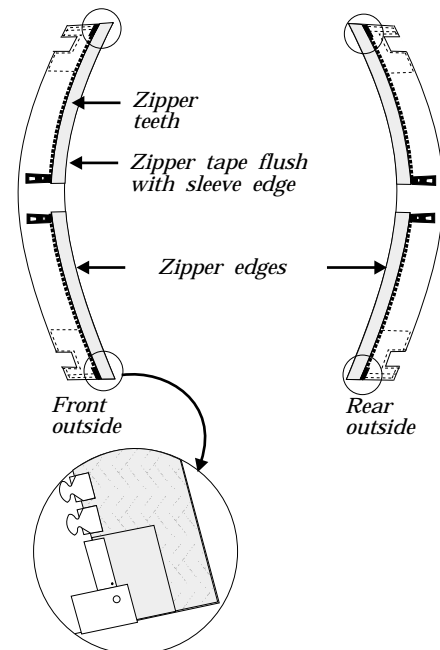
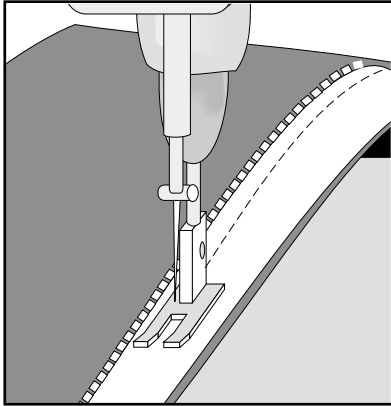

Figure 26



Sew with presser foot next to zipper teeth

Figure 28

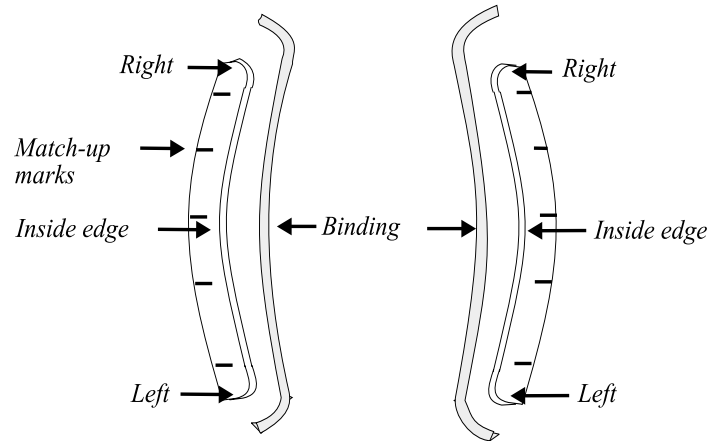
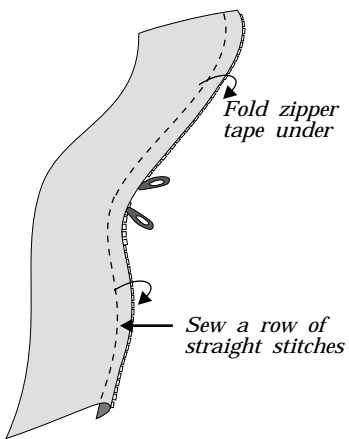

Figure 27



Fold zipper tape under

Sew a row of straight stitches

Figure 29

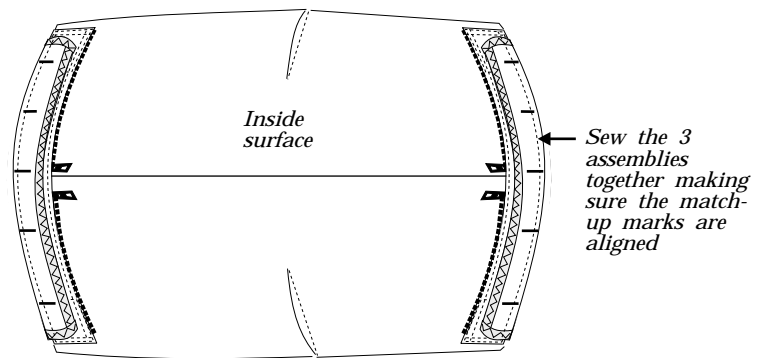

Sew the 3 assemblies together making sure the match-up marks are aligned

Lay the fore and aft sleeves and tails in position on the cover piece

Sew along the fore and aft edges of the Bimini securing all three layers together. Remove your staples as you sew. They will rust badly if left in place.

Return to the fore and aft sleeves. Sew the free edge of the zipper tape to the top with a single row of stitches. Be careful to keep the sleeve flat as this inside edge is sewn in place. The rear sleeve should be sewn with two gaps in the stitching 4 inches wide 18 inches from the center seam on each side. These gaps will be used as exit points for two webbing straps that run from the aft bow to the center one to hold it in place (Figure 30).

Figure 30

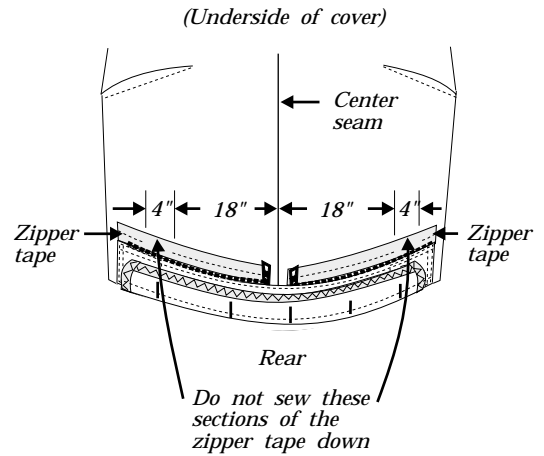

Sew a 7/8-inch wide binding tape all round the Bimini. This will finish all the exposed edges. We like to use a zigzag stitch for this binding, but a straight stitch can also be used if you are careful to place it near the inside edge of the binding on a consistent basis.

All that remains is the webbing straps. Four straps are used to support the Bimini. Two more are used from the aft bow to the center bow to hold it in position. These latter straps should be cut from 1-inch webbing 15 inches longer than twice the distance from the rear sleeve to the center bow. There should be a loop sewn into the webbing strap about 3/4 of the way along its length large enough to go round the frame tubing. On one short end of each strap, sew a 1-inch cam buckle into a small loop. Heat seal the other end so that it can be looped over the center bow and taken through the cam buckle for proper adjustment (Figure 31).

Figure 31

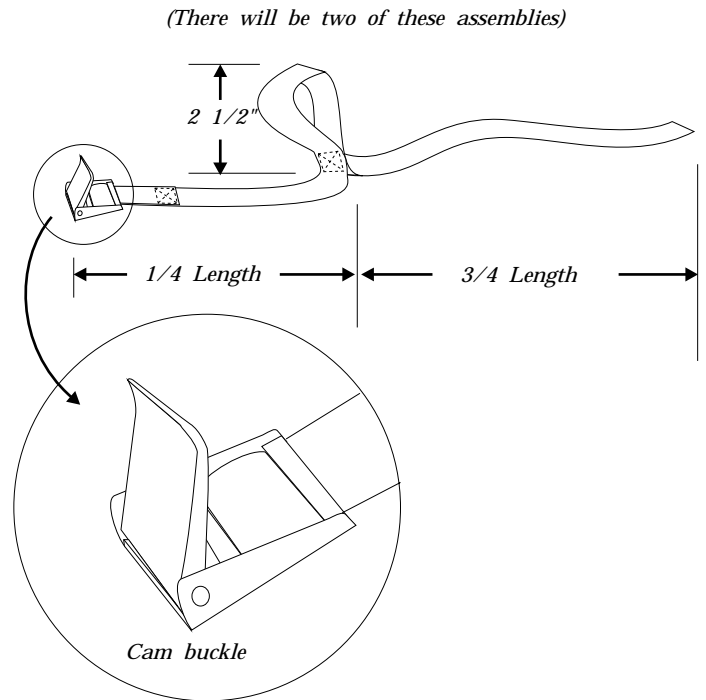

The fore and aft straps should be cut 3 times the length from the mounting point of the frame up the leg to the edge of the cover. Sew

a snap hook into a loop about 3/4 of the way along each webbing strap and, as before, a cam buckle into the short end. The other end of each strap can then be taken through the exit holes in the sleeves and back to the buckle for tensioning. Once again, heat seal the end of the webbing that will be fed into the buckle so that it does not ravel. The snap hooks will go into the four eye straps included with the frame kit and the long webbing leg will be taken into the sleeve cutout, round the tubing and back to the buckle for tensioning (Figure 32).

Congratulations—your Bimini is finished!

Figure 32

(There will be four of these assemblies)

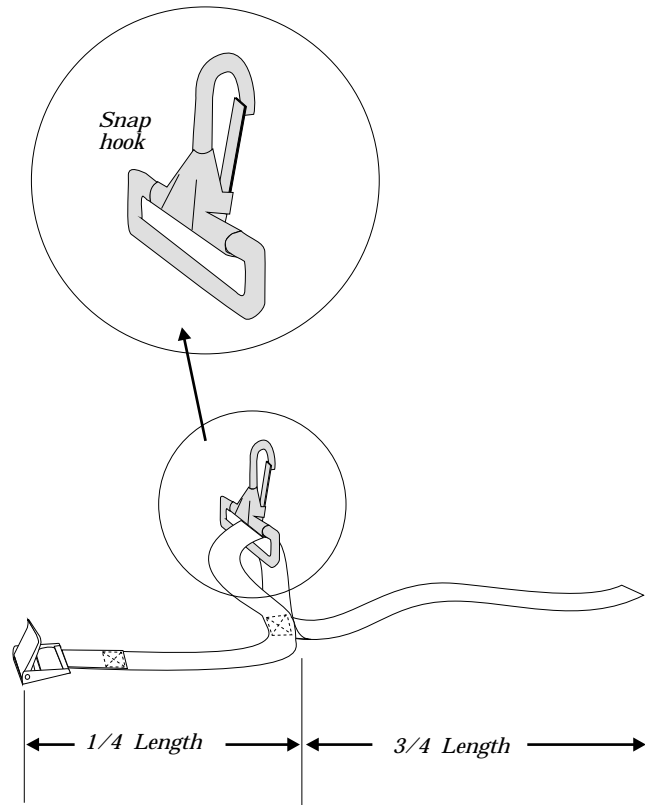

©1999
Sailrite Kits
305 W. Van Buren St.
Columbia City, IN 46725
All rights reserved

Fax (219) 244-4184
Phone (219) 244-6715
Tollfree 800-348-2769
www.sailrite.com

File J:\Instructions\BiminiManual\Bimini3.p65